

標 示 章		海灣國際科技股份有限公司 Baytek International Technology	文件 編號	
			版次	1.2
			頁次	共 12 頁

BT-OLC-PT23020 SERIES

SMD LED Component
PLCC2 Series
Lead (Pb) Free Product – RoHS Compliant

Mechanical Dimensions

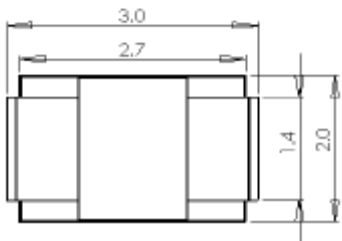
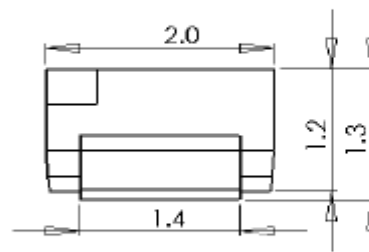
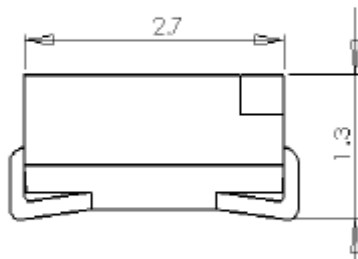
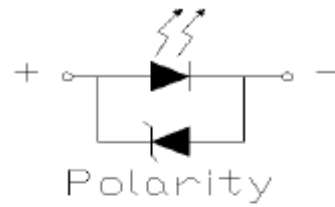
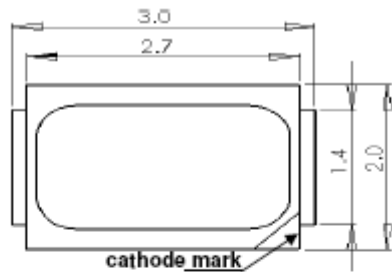

Notes

- All dimensions are in mm
- Tolerance: ± 0.1 mm

Features

- **Top view white LED (3.0 x 2.0 x 1.3mm)**
- **White SMT package**
- **Lead frame package with individual 2 pins**
- **InGaN with yellow phosphor**
- **Wide view angle (X : 120° / Y : 120°)**
- **IR reflow soldering**
- **ESD protection**
- **Pb free**
- **Green product, remain within RoHS**

Application

- **Backlight**
- **Decoration lighting**
- **Indicator**

PLCC2 3020 series Nomenclature

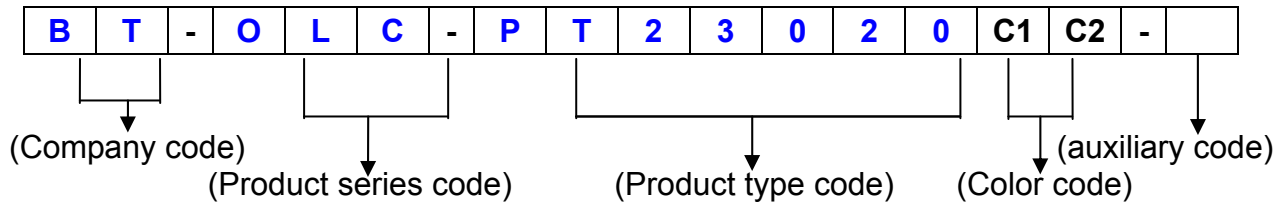

Luminous Intensity Characteristics, $T_a = 25^\circ\text{C}$, $I_F = 20\text{ mA}$

Part Number	Color	Luminous Intensity			Unit
		Min.	Typ.	Max.	
OLC-PT23020	NW	1000	---	2000	mcd
	WW	1000	---	1610	

- Luminous intensity is measured with an accuracy $\pm 10\%$

Forward Voltage Characteristics, $T_a = 25^\circ\text{C}$, $I_F = 20\text{ mA}$

Part Number	Color	Electrical Characteristics			Unit
		Min.	Typ.	Max.	
OLC-PT23020	NW	2.7	---	3.9	V
	WW	2.7	---	3.9	

- Forward Voltage is measured with an accuracy $\pm 0.05\text{V}$

Dominant Wavelength Characteristics, $T_a = 25^\circ\text{C}$, $I_F = 20\text{ mA}$

Part Number	Color	Optical Characteristics			Unit
		Min.	Typ.	Max.	
OLC-PT23020	NW	5500	---	10000	K
	WW	2700	---	5500	

Absolute Maximum Ratings

Part Number	P_d (mW)	I_F (mA)	I_{FP} (mA)	V_R (V)	I_R (μA)	T_{OP} ($^\circ\text{C}$)	T_{ST} ($^\circ\text{C}$)
OLC-PT23020NW	117	30	100	5	$<0.5@V_R=5$	$-40\sim+85$	$-40\sim+100$
OLC-PT23020WW							

- Condition for I_{FP} is pulse of 1/10 duty and 0.1msec width

Others

Items	Specification	Material	Quantity
Carrier tape	According to EIA 481-1A specs	Conductive black tape	2000pcs per reel
Reel	According to EIA 481-1A specs	Conductive black	
Label	BIT Standard	Paper	
Packing Bag	220 x 240mm	Aluminum laminated bag / no-zipper	One reel one bag
Carton	BIT standard	Paper	Non-specified

Luminous Intensity Ranks

Color	Bin Code	Minimum Photometric Flux (mcd)	Maximum Photometric Flux (mcd)
White	Y21	1000	1050
	Y22	1050	1125
	Z11	1125	1200
	Z12	1200	1270
	Z21	1270	1350
	Z22	1350	1440
	Z31	1440	1520
	Z32	1520	1610
	Z41	1610	1700
	Z42	1700	1800
	Z51	1800	1900
	Z52	1900	2000
	Warm White	Y21	1000
Y22		1050	1125
Z11		1125	1200
Z12		1200	1270
Z21		1270	1350
Z22		1350	1440
Z31		1440	1520
Z32		1520	1610

- Luminous intensity is measured with an accuracy of $\pm 10\%$

Color Bin

White Binning Structure Graphical Representation

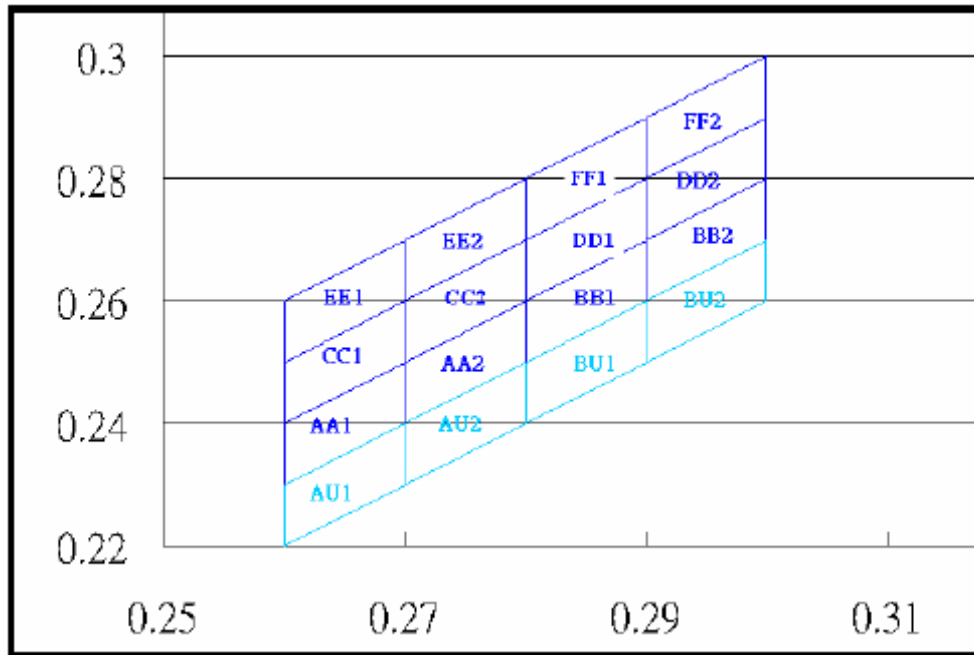

Note : Although several bins are outlined, product availability in a particular bin varies by production run and by product performance. Not all bins are available in all colors.

Warm White Binning Structure Graphical Representation

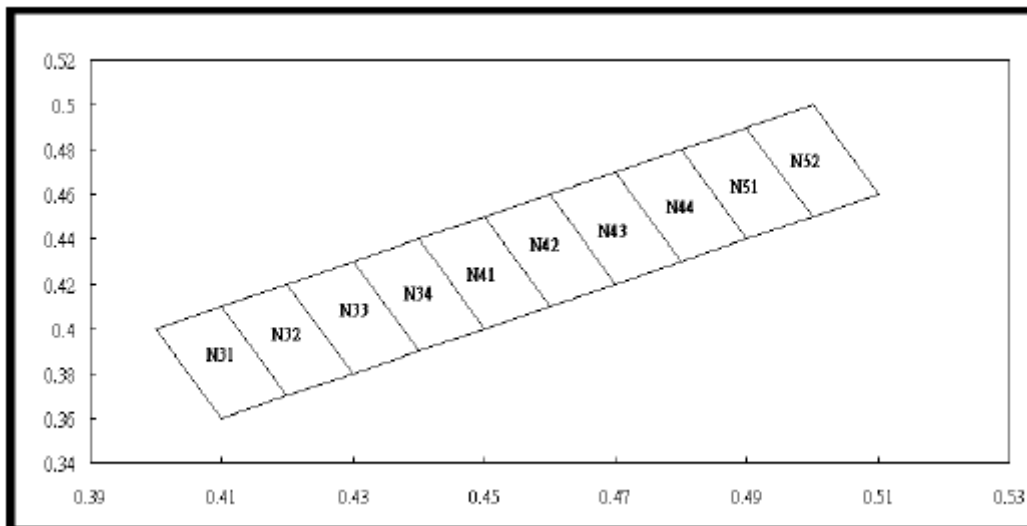

Note : Although several bins are outlined, product availability in a particular bin varies by production run and by product performance. Not all bins are available in all colors.

White Bin Structure

Bin Code	X	Y	Bin Code	X	Y
AU1	0.26	0.22	CC1	0.27	0.25
	0.27	0.23		0.27	0.26
	0.26	0.23		0.26	0.25
	0.27	0.24		0.26	0.24
AU2	0.27	0.24	CC2	0.28	0.26
	0.27	0.23		0.28	0.27
	0.28	0.24		0.27	0.26
	0.28	0.25		0.27	0.25
BU1	0.28	0.24	DD1	0.29	0.27
	0.29	0.25		0.29	0.28
	0.29	0.26		0.28	0.27
	0.28	0.25		0.28	0.26
BU2	0.29	0.25	DD2	0.30	0.28
	0.30	0.26		0.30	0.29
	0.30	0.27		0.29	0.28
	0.29	0.26		0.29	0.27
AA1	0.26	0.23	EE1	0.27	0.26
	0.27	0.24		0.27	0.27
	0.27	0.25		0.26	0.26
	0.26	0.24		0.26	0.25
AA2	0.27	0.24	EE2	0.28	0.27
	0.28	0.25		0.28	0.28
	0.28	0.26		0.27	0.27
	0.27	0.25		0.27	0.26
BB1	0.28	0.25	FF1	0.29	0.28
	0.29	0.26		0.29	0.29
	0.29	0.27		0.28	0.28
	0.28	0.26		0.28	0.27
BB2	0.29	0.26	FF2	0.30	0.29
	0.30	0.27		0.30	0.30
	0.30	0.28		0.29	0.29
	0.29	0.27		0.29	0.28

- If color binning is required, only one color group is allowed for each chip within a reel.
- Chromaticity coordinate group are measured with an accuracy of ± 0.01 .
- Color coordinate is derived from the CIE 1931 chromaticity.

Warm White Bin Structure

Bin Code	X	Y	Bin Code	X	Y
N31	0.41	0.36	N42	0.46	0.41
	0.40	0.40		0.45	0.45
	0.41	0.41		0.46	0.46
	0.42	0.37		0.47	0.42
N32	0.42	0.37	N43	0.47	0.42
	0.41	0.41		0.46	0.46
	0.42	0.42		0.47	0.47
	0.43	0.38		0.48	0.43
N33	0.43	0.38	N44	0.48	0.43
	0.42	0.42		0.47	0.47
	0.43	0.43		0.48	0.48
	0.44	0.39		0.49	0.44
N34	0.44	0.39	N51	0.49	0.44
	0.43	0.43		0.48	0.48
	0.44	0.44		0.49	0.49
	0.45	0.40		0.50	0.45
N41	0.45	0.40	N52	0.50	0.45
	0.44	0.44		0.49	0.49
	0.45	0.45		0.50	0.50
	0.46	0.41		0.51	0.46

- If color binning is required, only one color group is allowed for each chip within a reel.
- Chromaticity coordinate group are measured with an accuracy of ± 0.01 .
- Color coordinate is derived from the CIE 1931 chromaticity.

Characteristics Curves

White / Warm White

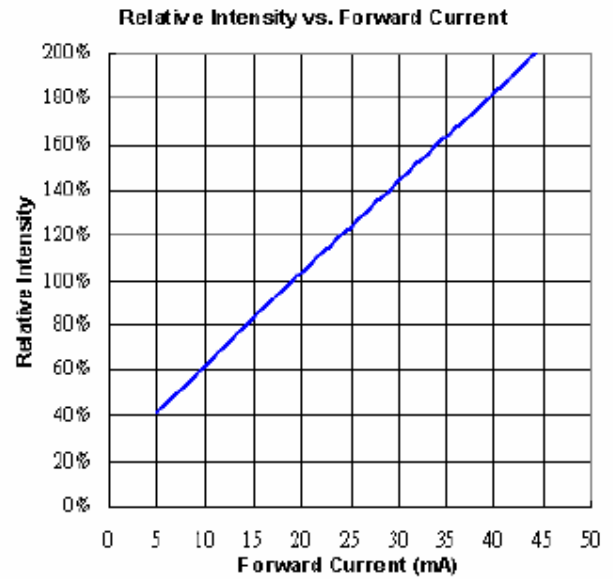
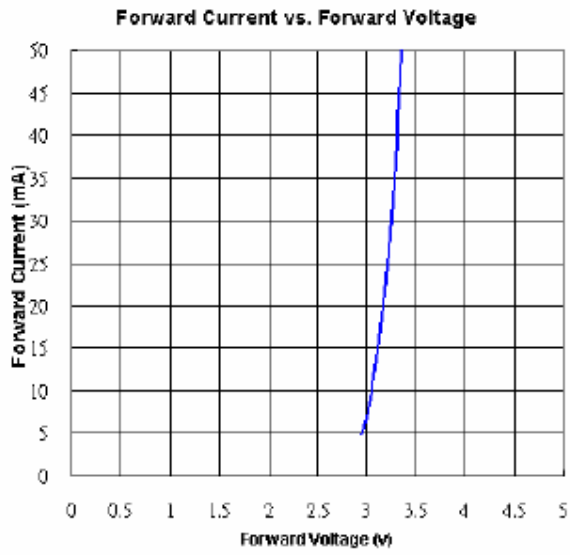

Directive Characteristics

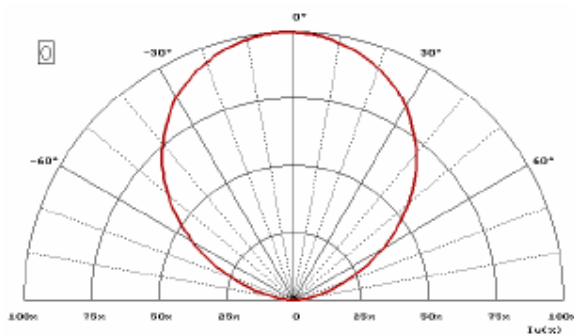

Directive Characteristics

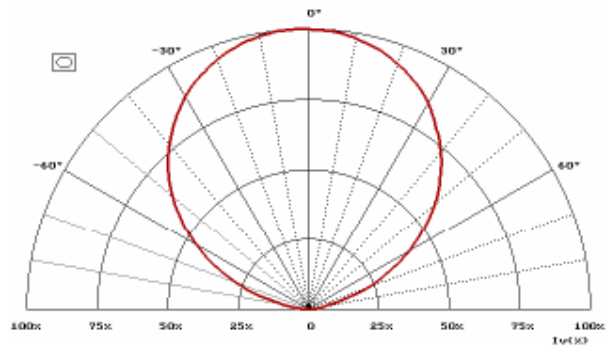

Packing Tape, Reel, and Packing Model

Tape Dimension

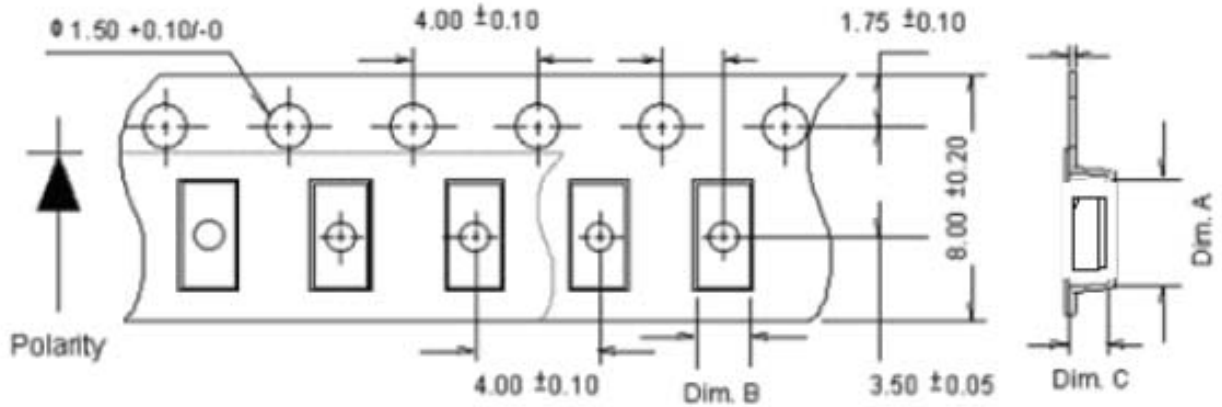

Part No.	Dim. A	Dim. B	Dim. C	Q'ty / Reel
PT23020	3.30 ± 0.10	2.25 ± 0.10	1.65 ± 0.10	2K

Unit: mm

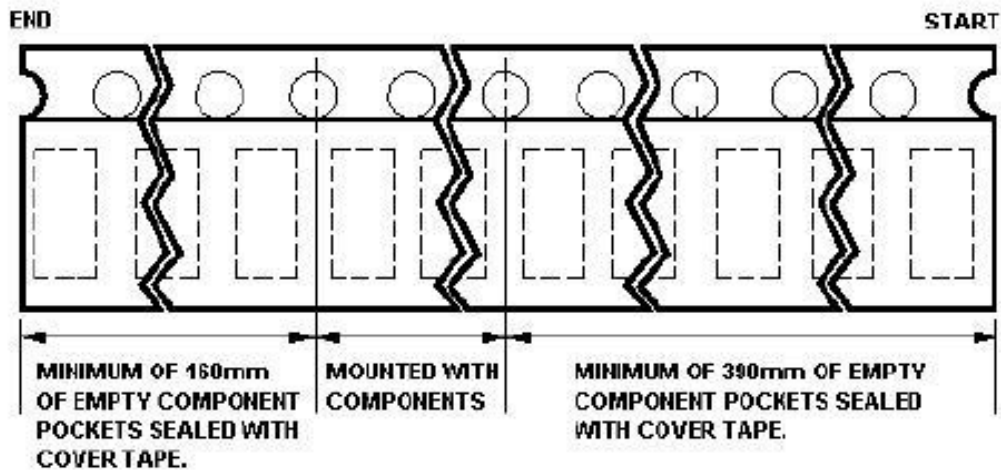

Reel Dimension

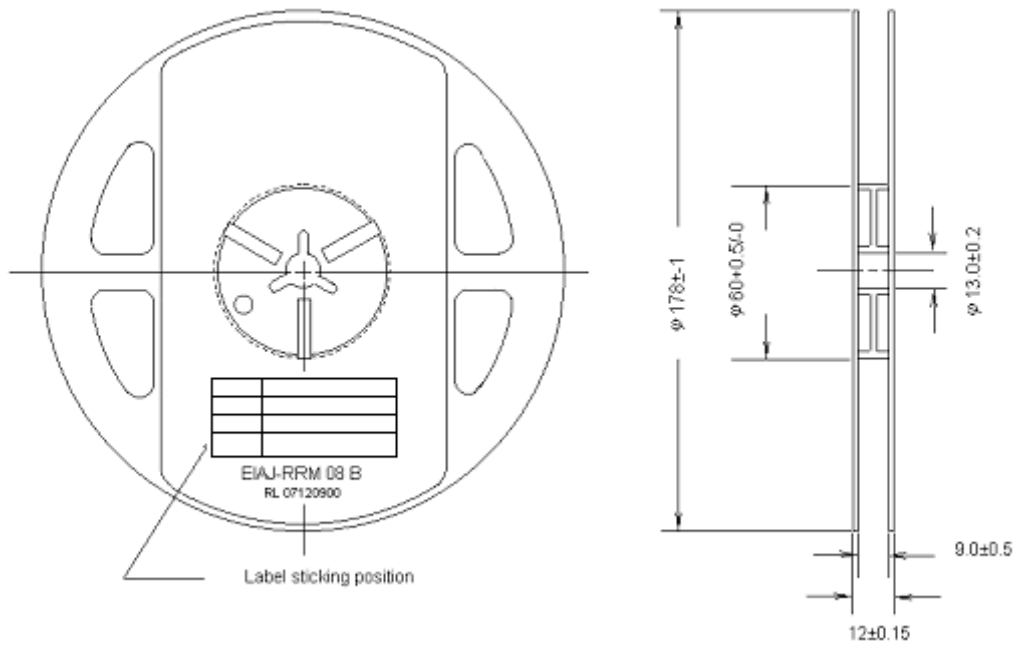

Packing

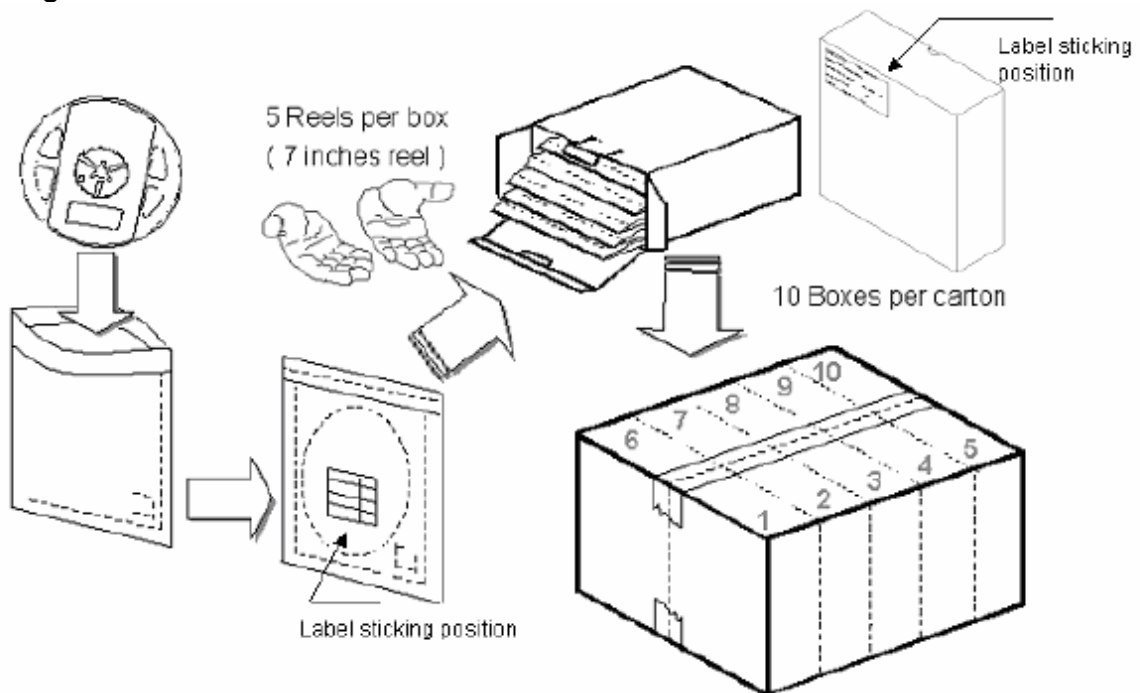

5 boxes per carton is available depending on shipment quantity.

Dry Pack

All SMD optical devices are **MOISTURE SENSITIVE**. Avoid exposure to moisture at all times during transportation or storage. Every reel is packaged in a moisture protected anti-static bag. Each bag is properly sealed prior to shipment.

Upon request, a humidity indicator will be included in the moisture protected anti-static bag prior to shipment.

The packing sequence is as follows:

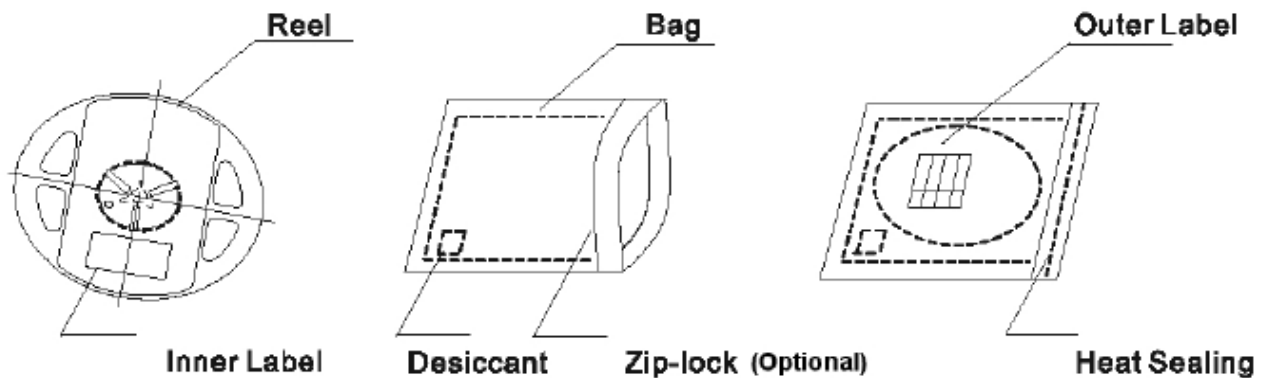

PRECAUTIONS

- Avoid exposure to moisture at all times during transportation or storage.
- Anti-Static precaution must be taken when handling GaN, InGaN, and AlInGaP products.
- It is suggested to connect the unit with a current limiting resistor of the proper size. Avoid applying a reverse voltage beyond the specified limit.
- Avoid operation beyond the limits as specified by the absolute maximum ratings.
- Avoid direct contact with the surface through which the LED emits light.
- If possible, assemble the unit in a clean room or dust-free environment.

Reflow Soldering

Recommend soldering paste specifications:

- Operating temp.: Above 220 ° C, 60 sec.
- Peak temp.:260 ° C Max., 10sec Max.
- Never attempt next process until the component is cooled down to room temperature after reflow.
- The recommended reflow soldering profile (measured on the surface of the LED terminal) is as following:

Lead-free Solder Profile

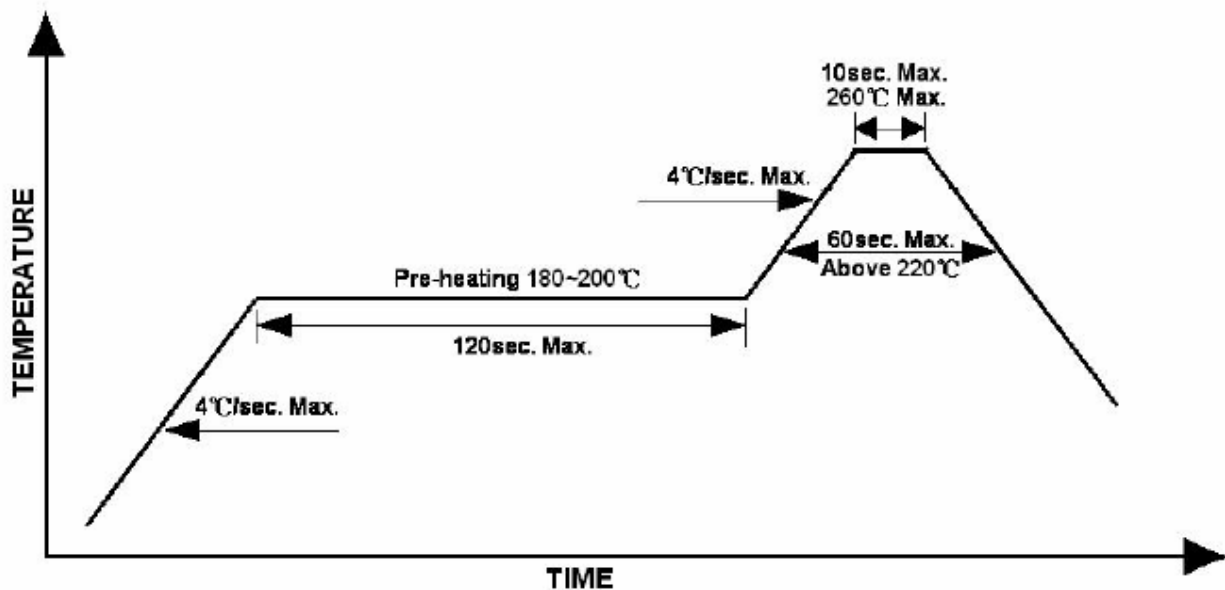

Reworking

- Rework should be completed within 5 seconds under 260 ° C.
- The iron tip must not come in contact with the copper foil.
- Twin-head type is preferred.

Cleaning

Following are cleaning procedures after soldering:

- An alcohol-based solvent such as isopropyl alcohol (IPA) is recommended.
- Temperature x Time should be 50 ° C x 30sec. or < 30 ° C x 3min
- Ultrasonic cleaning: < 15W/ bath; bath volume ≤ 1liter
- Curing: 100 ° C max, <3min

Cautions of Pick and Place

- Avoid stress on the resin at elevated temperature.
- Avoid rubbing or scraping the resin by any object.
- Electric-static may cause damage to the component. Please ensure that the equipment is properly grounded. Use of an ionizer fan is recommended.